

The da Vinci Surgical System enables surgeons to operate with unmatched precision and control using only a few small incisions. Recent studies suggest that da Vinci Prostatectomy may offer improved cancer control and a faster return to potency and continence. Da Vinci Prostatectomy also offers these potential benefits:

- ✓ Significantly less pain
- ✓ Less blood loss
- ✓ Fewer complications
- ✓ Less scarring
- ✓ A shorter hospital stay
- ✓ Faster return to normal daily activities

If you are a candidate for prostate surgery, talk to a surgeon who performs da Vinci Prostatectomy.

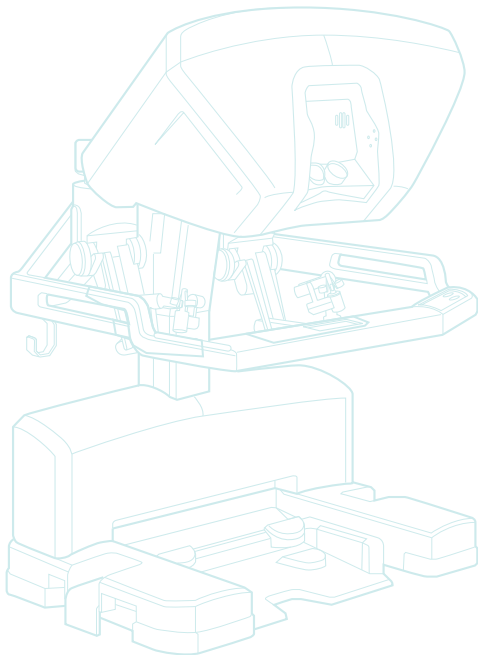

Contact information

For a list of da Vinci surgeons practicing at Millard Fillmore Suburban Hospital, visit www.Suburbandavinci.com or

Phone: (716) 568-6889

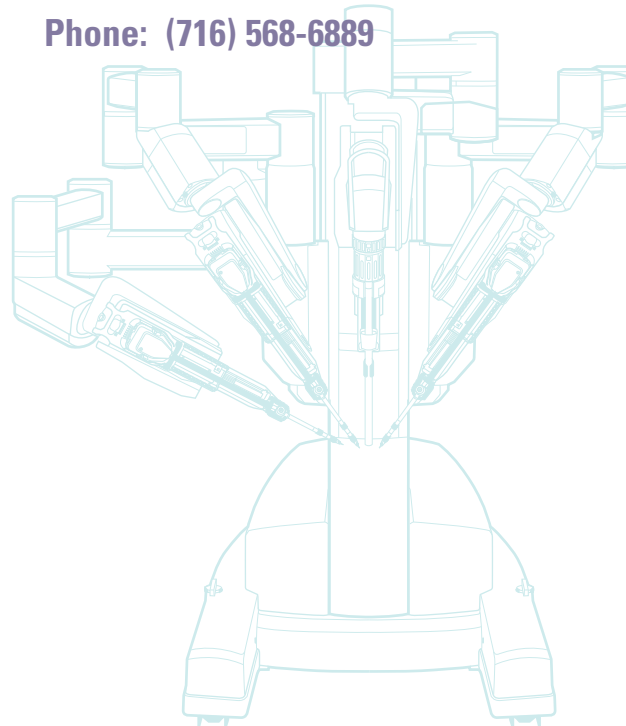

Visit us online at
www.kaleidahealth.org

Language assistance services are available free of charge for anyone who has a need for an interpreter.

Tenemos servicios de ayuda en Español, para cualquiera que necesita un intérprete.

The Future of
Surgery is Here...

*Robotic Assisted
Urologic Surgery*

PROGRAM



The Newest Technology in Surgery Today

Millard Fillmore Suburban Hospital is committed to offering physicians and patients every option to ensure the very best in patient care. That is why we are happy to offer da Vinci robotic assisted surgery to patients that require urologic surgery.

When medication and other non-surgical treatments are either unavailable or cannot relieve symptoms, surgery is the accepted treatment for a broad range of conditions that affect the male reproductive organs and the organs of the urinary tract. These conditions include, but are not limited to, prostate cancer, ureteropelvic junction (UPJ) obstruction, bladder and kidney cancer and vesicoureteral reflux.

Facing any kind of urologic surgery creates a great deal of anxiety for most men. Among your concerns is: "Will my body function normally following surgery?"

Traditional open urologic surgery – in which large incisions are made to access the pelvic organs – has been the standard approach when surgery is warranted. Yet common



drawbacks of this procedure include significant post-surgical pain, a lengthy recovery and an unpredictable, potentially long-term impact on continence and sexual function.

Fortunately, less invasive surgical options are available to many patients facing urologic surgery. The most common of these is laparoscopy, which uses small incisions. While laparoscopy can be very effective for many routine procedures, limitations of this technology prevent its use for more complex urologic surgeries.

A new category of surgery, introduced with the development of the da Vinci® Surgical System, is being used by an increasing number of surgeons worldwide for prostatectomy and other urologic procedures. This minimally invasive approach, utilizing the latest in surgical and robotics technologies, is ideal for delicate urologic surgery. This includes prostatectomy, in which the target site is not only tightly confined but also surrounded by nerves affecting urinary control and sexual function. Using da Vinci, your surgeon has a better tool to spare surrounding nerves, which may enhance both your recovery experience and clinical outcomes.

da Vinci Prostatectomy

Referred to by many as robotic surgery for prostate cancer or robotic prostatectomy, da Vinci® Prostatectomy is more accurately a robot-assisted, minimally invasive surgery that is quickly becoming the preferred treatment for removal of the prostate following early diagnosis of prostate cancer. In fact, studies suggest that da Vinci Prostatectomy may be the most effective, least invasive prostate surgery performed today.

da Vinci ^{HD}
SURGICAL SYSTEM

Though any diagnosis of cancer can be traumatic, the good news is that if your doctor recommends prostate surgery, the cancer was probably caught early. And, with da Vinci Prostatectomy, the likelihood of a complete recovery from prostate cancer without long-term side effects is, for most patients, better than it has ever been.

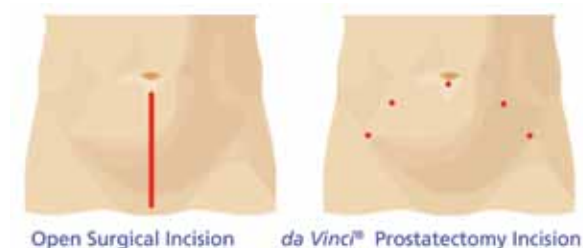

da Vinci Prostatectomy is performed with the assistance of the da Vinci Surgical System – the latest evolution in robotics technology.